

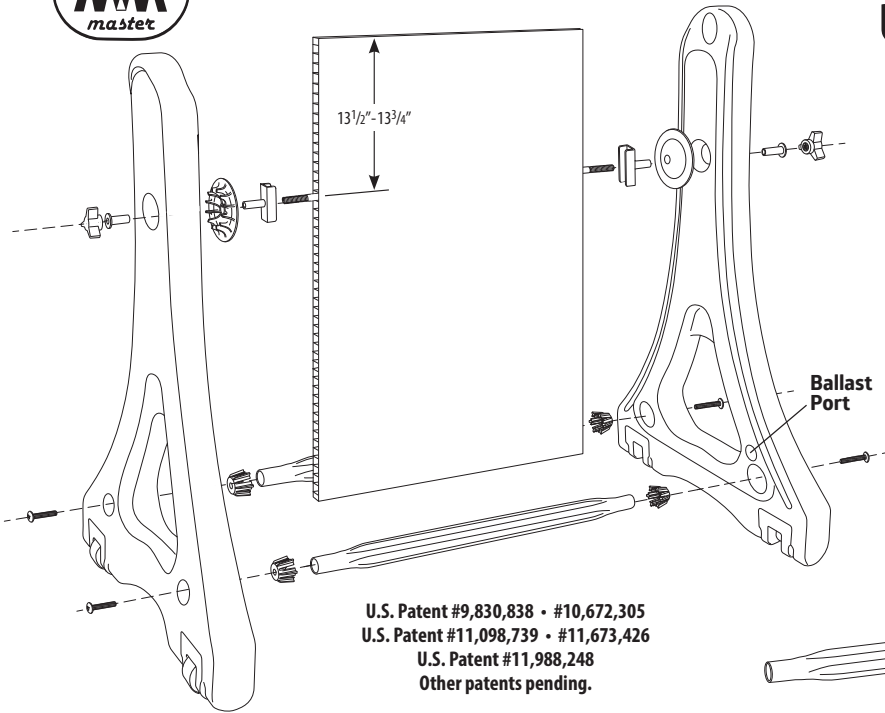

Uni-Leg® Swinger Plus® Sidewalk and Roadside Models

USER GUIDE



U.S. Patent #9,830,838 • #10,672,305
U.S. Patent #11,098,739 • #11,673,426
U.S. Patent #11,988,248
Other patents pending.

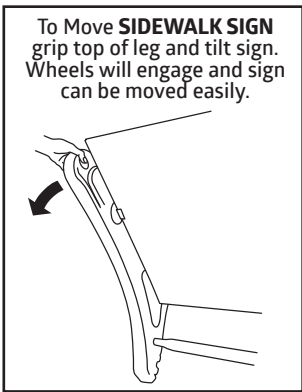
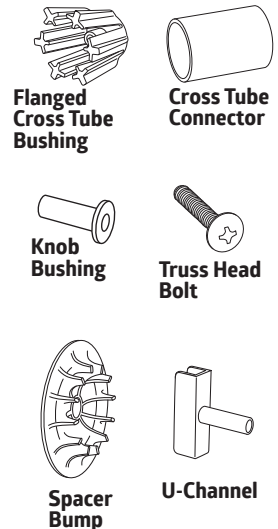

To Move **SIDEWALK SIGN** grip top of leg and tilt sign. Wheels will engage and sign can be moved easily.

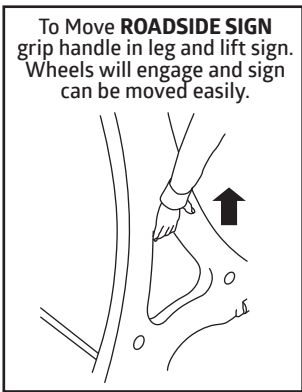

To Move **ROADSIDE SIGN** grip handle in leg and lift sign. Wheels will engage and sign can be moved easily.

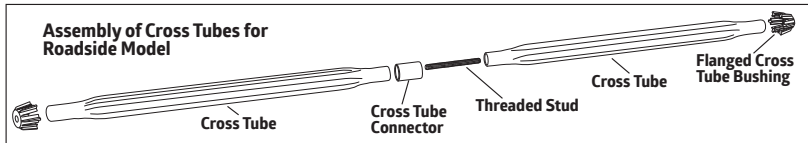

SIDEWALK MODEL ASSEMBLY

- On a level surface attach bottom **Cross Tubes** to **Sign Legs** using **Flanged Cross Tube Bushing** and **Truss Head Bolts**.
- Put **Flanged Cross Tube Bushing** onto ends of **Cross Tubes** (small end in).
- Slide **Cross Tube** with **Flanged Cross Tube Bushing** into the deep recess on bottom of **Sign Leg**.
- Insert **Truss Head Bolt** from outside and tighten.
- Repeat until both **Cross Tubes** are in place on the bottom of both **Sign Legs**.

ROADSIDE MODEL ASSEMBLY

- Assemble **Double Cross Tubes** first.
- Install the **Threaded Stud** into one end of the **Cross Tube**; make sure the red colored thread locker patch on the thread engages, then insert in the tube.
- Slide the **Cross Tube Connector** over the end with the **Threaded Stud**. Insert the second **Cross Tube** and tighten firmly.
- On a level surface attach bottom **Double Cross Tubes** to **Sign Legs** using **Flanged Cross Tube Bushing** and **Truss Head Bolts**. See **SIDEWALK MODEL ASSEMBLY**.

Installation of Sign Face of SIDEWALK and ROADSIDE models

- First, for wind resistance up to 30+ MPH add 3-4 quarts of water or sand to each **Sign Leg** through the **Ballast Port** on the inside of the **Sign Leg** by removing the Cap. Sandbags can also be placed across the bottom oval or the sign can be attached to ground stakes.
- Then measure 13 1/2" - 13 3/4" (35 cm) down from top of sign face and mark edge. This is where the **Threaded Cross Rod** will slide through **Sign Panel**.
- Attach **Sign Panel** to **Sign Legs** using **U-channels**, **Spacer Bump**, **Knob Bushings**, **Threaded Cross Rod** and **Knobs**. See illustration.
- Attach **Knob** to one end of **Threaded Cross Rod**.
- Slide on **Knob Bushing**, large flat face against **Knob**.
- Insert **Threaded Cross Rod** into hole at top of the **Sign Leg** from outside edge.
- Slide on **Spacer Bump** onto **Threaded Cross Rod**, fingers facing into deep recess on the inside of the **Sign Leg**.

- Slide **U-Channel** onto **Threaded Cross Rod**, bushing going into **Spacer Bump**.
- Insert the **Sign Panel** onto the **Threaded Cross Rod** at mark 13 1/2" - 13 3/4" (35 cm) from top of **Sign Panel**.
- Slide **U-Channel** onto other side of **Sign Panel** facing in.
- Slide **Spacer Bump** onto **Threaded Cross Rod**, bump facing **Sign Panel**.
- Insert **Threaded Cross Rod** into hole at top of other **Sign Leg**.
- Slide on **Knob Bushing**, large flat face out.
- Install **Knob** on end of **Threaded Cross Rod** and tighten firmly; make sure **Sign Panel** sits in **U-Channels**.
- To move the 'SWINGER-plus®' Sidewalk model just Grip the top of the Sign Leg, Tip the sign back to engage the wheels and pull to Roll in, out or about. For the Roadside model grip the **Hand Hold** at the top of the triangular cut out in the leg and lift to engage wheels and Roll in, out or about.

HELPFUL HINTS

- For more interest put a different message on each side of the sign.
- For more variety make reversible sign faces by decorating both sides or the sign face so that the customer can change the message and keep a fresh look.
- Combine graphics with letter tracks and changeable letters or headers to create a custom Message Board sign.
- Keep message short and simple for maximum impact.
- 'SWINGER®' sidewalk curb/roadside signs are designed for winds up to 30-40 mph. In the event of higher winds bring sign inside or add more ballast.

